

# **SHIPPING AND PACKAGING INSTRUCTIONS COMPLIANCE**

**UPDATED TO 2019**

## GENERAL REMARKS

All deliveries to our companies must be made in compliance with following instructions. These shipping and packaging instructions are invalid only if we provide different instructions in specific cases.

## PURCHASING ORDERS-SALES CONFIRMATION

Each order line of Inox Mare indicates a small box and master carton quantity. This information must always be part of your S/C as well.

## PACKING LIST

Every pallet must have a packing list copy attached. This copy must be inside a transparent plastic envelop attached to the pallet. Packing List must contain following information:

- Pallet number
- Inox Mare item code
- Item description
- Item quantity
- Small box quantity
- Master carton quantity
- Number of master carton
- Number of small boxes
- Supplier Ident. Number
- Different quantities for one item should be listed in sequence
- Order number.





## **TRANSPORT DOCUMENTS AND CERTIFICATES**

All transport documents (Invoice, detailed Packing List, Bill of Lading, Certificate of Origin, Chemical analysis and Dimensional report, Mill Certificate of raw material composition, Mechanical Test) must be anticipated by fax/e-mail to Inox Mare (...@inoxmare.it) Purchasing Dept., and then sent in Original by Express Courier (latest 2 weeks after B/L issue date) to following address:

Inox Mare INOX MARE S.r.l.  
Via Pomposa, 51/i  
47923 – Rimini (RN)  
ITALY

Current forwarder

## **PACKAGING**

Every wooden packaging, pallet included, must comply with IPPC-ISPM n.15 standard. Items must be packed into good quality (suitable for further sales and transport) carton small boxes according qty indicated on Inox Mare P.O., then put into master carton. If any damage should occur to the goods during transport because of inadequate packaging, supplier will bear all related costs. Every small box and master carton must have an attached label, made according Inox Mare instructions.

# MASTER CARTON

Master carton sizes has to be as follows:

**28x24x17**

Max. 20 kg per master carton.

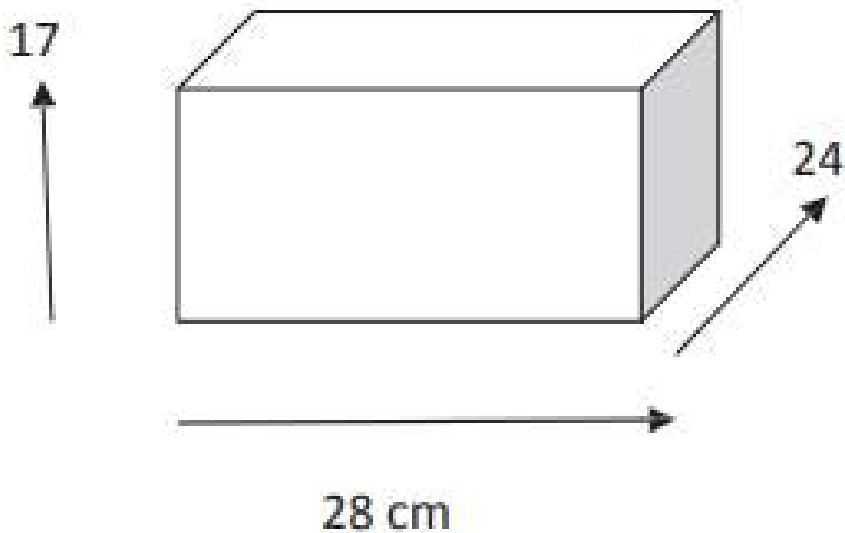

# FULL PALLET

Cartons must be loaded on undamaged EURO flat pallets: 800\*1200\*144 mm

EURO PALLET "EPAL" as you can see on picture below.





It has to be composed by 36 master cartons, put on 3 pile master carton for every pallet.

4 line of master carton on side 120 cm.



3 line of master carton on side 80 cm.



Wrapped reinforced pallet.



Pallet has to be wrapped with plastic film. The pallet must be secured by four cardboard or wood angle bars at the angles. No plastic or metallic band is allowed as you can see on picture below. Pallet height must be max 650 mm. (20 mm. tolerance), EURO pallet included, without overlap or protrusion out the sides. Pallet and load must not exceed 800 Kg. Every full pallet must consist of only one item.

# MIXED PALLET

In case of mixed pallets, items may not be overlapped.

Every color corresponds to one item:

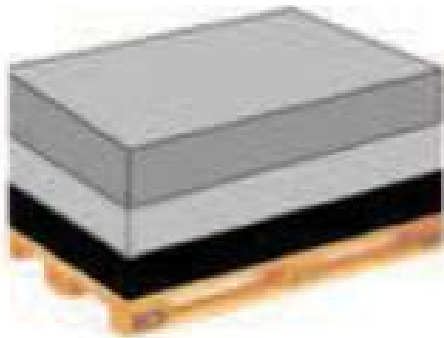

WRONG

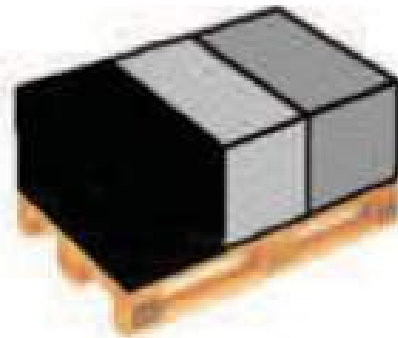

OK



# FINAL REMARKS

Our warehouse staff will check your commitment to the packaging instructions at receipt of the goods.

# 1

Supplier will bear all costs connected with:

- wrong or missing P.O. number
- wrong or missing item number
- wrong items
- wrong or missing packing list
- poor quality carton
- missing master carton
- wrong labels
- wrong packaging
- missing qty
- small boxes with washers have to be sealed with adhesive tape.

# 2

Every noncompliance with our shipping instructions regarding the transport documents will be penalized with 200 € per shipment.

# 3

Whenever possible Inox Mare order full pallet qty in order to keep the logistical process simple. When such qty is ordered and confirmed no partial qty is allowed to be dispatched. For example: total order qty is 200.000 pcs., 1 pallet contains 50.000 pcs. It is not allowed to dispatch 30.000 or 62.000 pcs. Possible dispatch qty is 50.000, 100.000, 150.000 or 200.000 pcs. Each noncompliance will be penalized with 200 €.

